

# Delta VCF



## $\Delta$ VCF v2 - Wiring Guide

2009 MegaOhmAudio

# VCF Audio Related Inputs and Controls

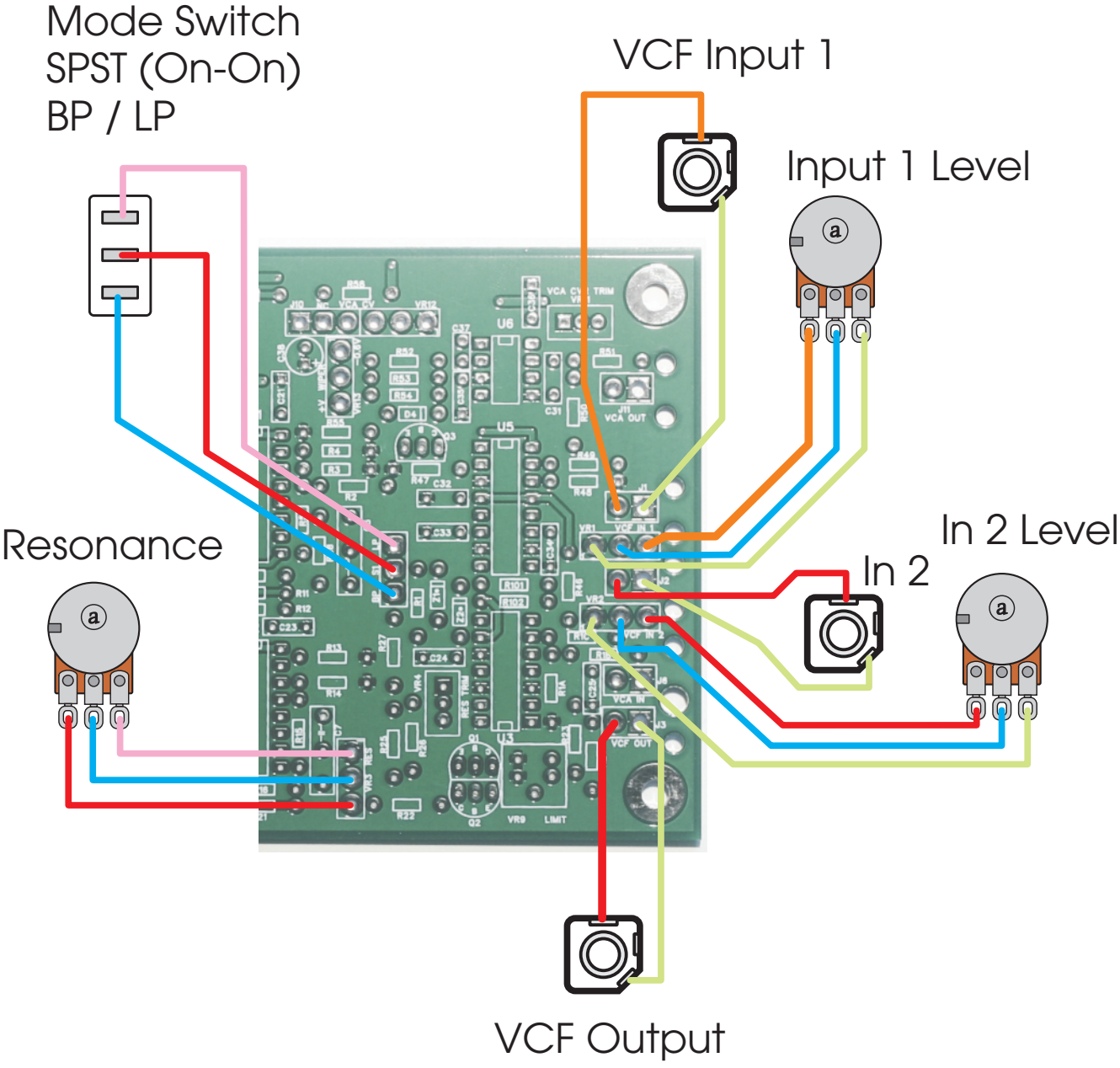



# VCA Controls and Inputs

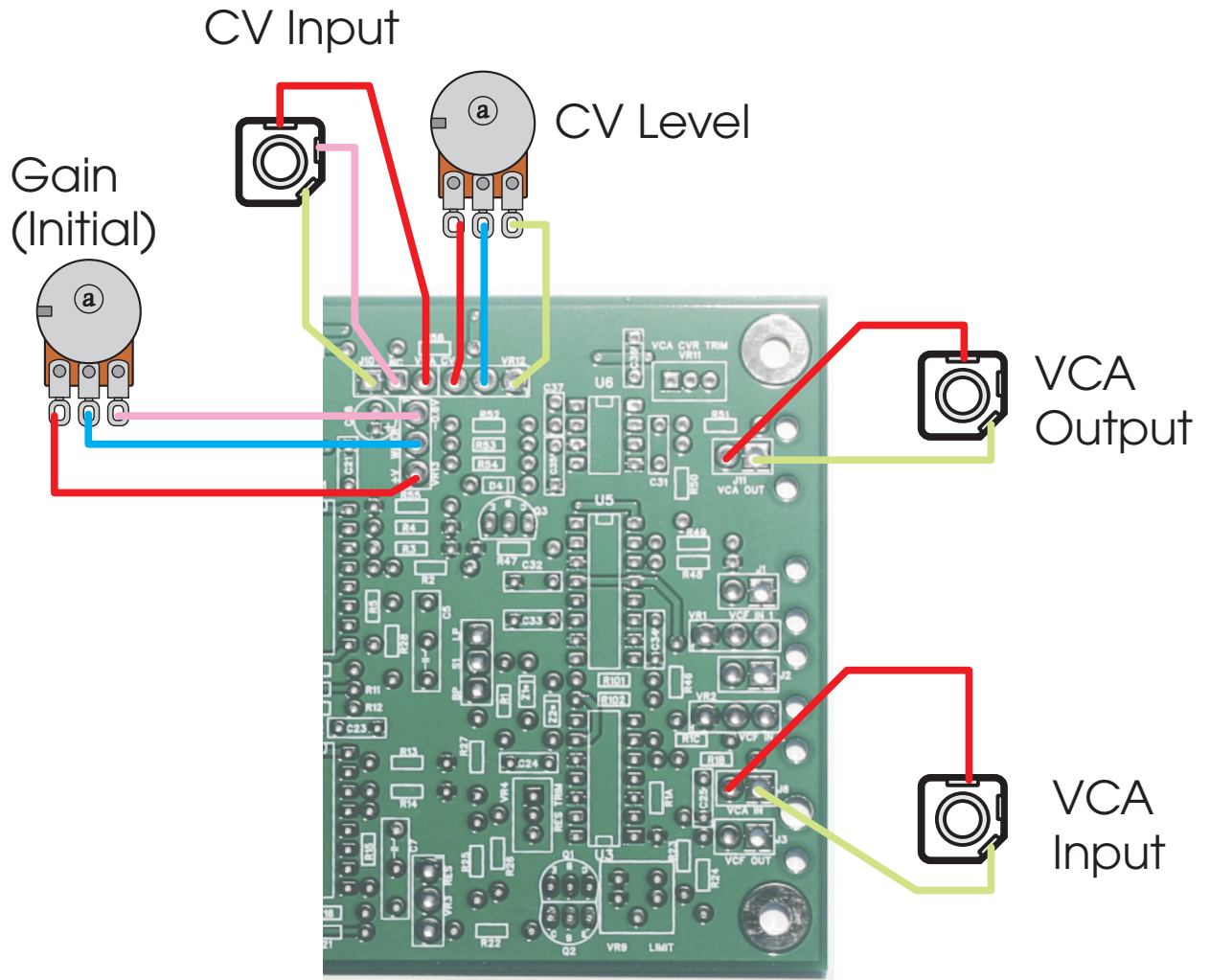

If you are including a Gain / Initial pot then do NOT connect the NC pad to the Switch pin of the CV input jack. Leave the Switch pin open or tie it to ground.

All Green wires are ground

rear view

side view

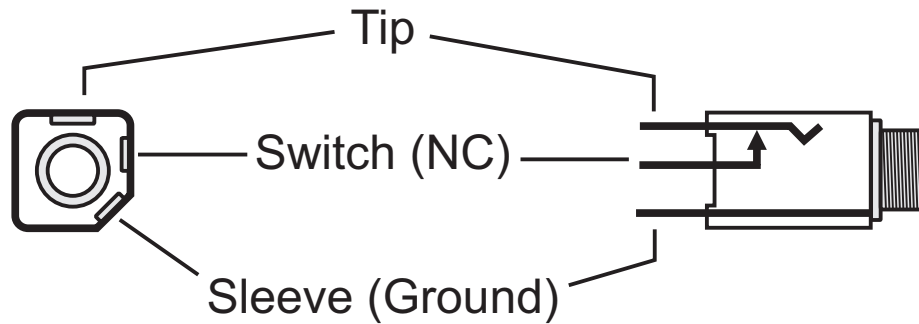

---

Rear view of an Alpha pot (left) and a sealed pcb mount pot (right). Pins are numbered in descending order when looking at the back of a pot.

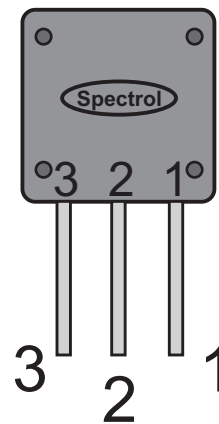
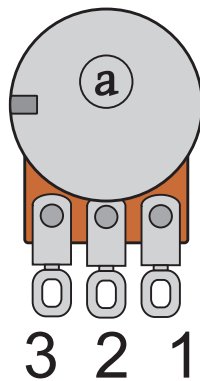

On the pcb, the pot pads are surrounded by a silk screened rectangle. There is a *very* small number '1' in this rectangle. This pad is wired to pin 1 of the pot. The center pad is always connected to the wiper. The unmarked pad is wired to pin 3 of the pot.